

Safety Stop Function Instruction Manual

CONTENTS

| | |
|---|-----------|
| 1. GENERAL DESCRIPTION | 2 |
| 2. INSTALLATION AND WIRING..... | 3 |
| 3. EXAMPLE OF SAFETY SYSTEM CONFIGURATION | 7 |
| 4. TEST AND CHECKING FAILURE | 10 |
| 5. SAFETY PARAMETERS OF FR-A800 | 11 |

Compliance with the EU Machinery Directive – Functional Safety

WARNING

- Any misuse of safety function could lead to personal injury or death, property damage, or economic loss. To ensure that the system complies fully with requirement of safety, make a system-level risk assessment. Mitsubishi Electric Co. cannot assume responsibility for any system to comply with safety directive.

CAUTION

- The information of this manual is merely a guide for proper installation.
- Mitsubishi Electric Co. cannot assume responsibility for the compliance or the noncompliance to any code, national, local or otherwise for the proper installation of this equipment.
- A hazard of personal injury and/or equipment damage exists if codes are ignored during installation.

WARNING

- To avoid an electric shock hazard, verify that the voltage on the bus capacitors has discharged before performing any work on the drive. Measure the DC bus voltage at the P(+) and N(-) terminals or test points (refer to your drive's [User Manual](#) for locations and discharging time). The voltage must be zero.

WARNING

- The safety stop function do not isolate electrically between drive and motor. To avoid an electric shock hazard, disconnect/isolate power to the drive and verify to ensure that the voltage is zero before performing any work on the motor (refer to your drive's [User Manual](#) for discharging time).

1 GENERAL DESCRIPTION

Features

Mitsubishi FR-A800 safety stop function prevents a drive from supplying rotational energy to motors. Dual safety channels 'S1' and 'S2' cut off the gate-drive power for IGBT to turn off.

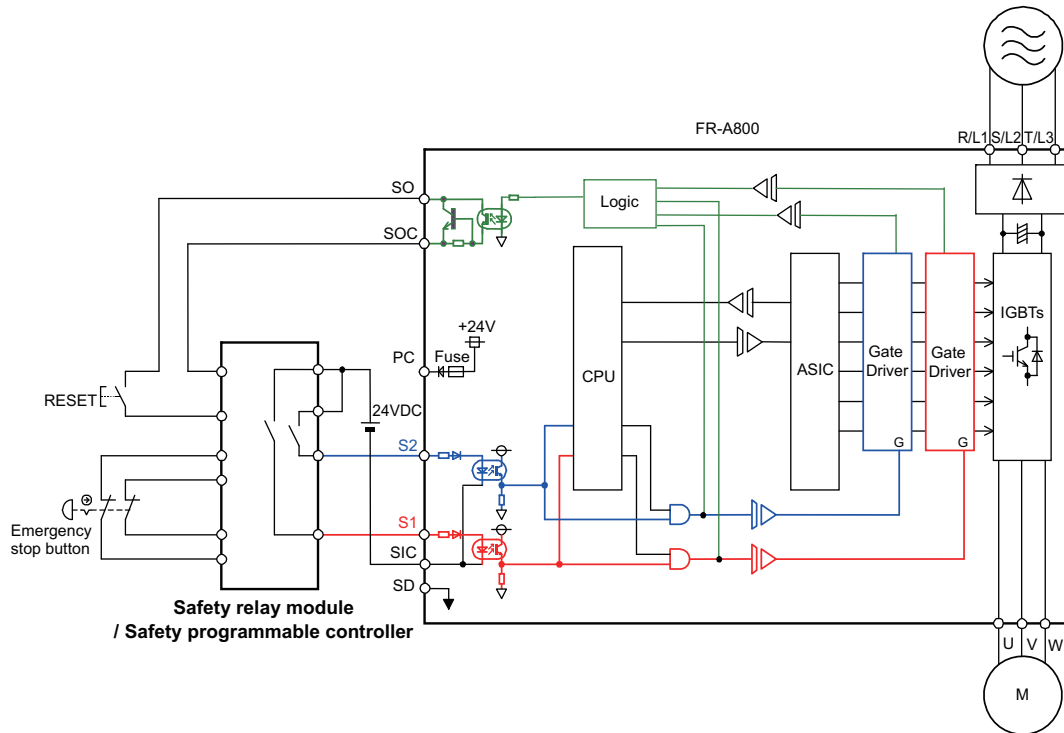

Fig.1 FR-A800 safety stop function diagram

! WARNING

- Disconnecting the power to the gate driver by the safety stop function does not isolate electrically between drive and motor. To avoid an electric shock hazard, disconnect power to the drive and verify that the main circuit capacitor voltage is zero (across P and N terminals) before performing any work on the motor (refer to your drive's [User Manual](#) for discharging time).

Standards

Mitsubishi FR-A800 safety stop function meets the following directives and categories.

ISO13849-1:2008 Category 3/PLd

IEC62061:2005 / IEC61800-5-2:2007 / IEC61508 SIL2

IEC60204-1:2010 / IEC61800-5-2:2007 Stop category 0

! WARNING

- The misuse of safety function leads to personal injury or death, property damage, or economic loss. To ensure that the system complies fully with requirement of safety, make a system-level risk assessment. Mitsubishi Electric Co. cannot assume responsibility for any system to comply with safety directive.

2 INSTALLATION AND WIRING

⚠ CAUTION

- The following information is merely a guide for proper installation.
- Mitsubishi Electric Co. cannot assume responsibility for the compliance or the noncompliance to any code, national, local or otherwise for the proper installation of this equipment.
- A hazard of personal injury and/or equipment damage exists if codes are ignored during installation.

⚠ CAUTION

- Ensure the safety relay unit and the FR-A800 unit is mounted closely in enclosure meeting IP54 and all interconnection wiring is short and protected against open and short circuit faults. Refer ISO/IEC13849-2.

Installation

Mitsubishi FR-A800 safety stop function should be used under following condition and environment.

Table.1 The condition and environment for using safety stop function

| Item | | Condition |
|-----------------------------|------------------------------|--|
| Surrounding air temperature | LD, ND (initial setting), HD | -10°C to +50°C (non-freezing) |
| | SLD | -10°C to +40°C (non-freezing) |
| Storage temperature | | -20°C to +65°C *1 |
| Ambient humidity | | With circuit board coating: 95% RH or less (non-condensing), Without circuit board coating: 90% RH or less (non-condensing) |
| Vibration | | 5.9m/s ² or less at 10 to 55Hz (directions of X, Y, Z axes) |
| Altitude | | Maximum 2500 above sea level *2 |
| Atmosphere | | Indoors (free from corrosive gas, flammable gas, oil mist, dust and dirt) |
| Over voltage category | | III or less |
| Pollution degree | | II or less |
| Mounting | | Wall mounting / vertical orientation |

*1 Temperature applicable for a short time, e.g. in transit.

*2 For the installation at an altitude above 1,000 m (3280.80 feet) up to 2,500 m (8202 feet), derate the rated current 3% per 500 m (1640.40 feet).

CAUTION

- In order to meet safety stop, an approved safety relay unit to ISO13849-1 safety category 3 or better shall be used in conjunction with FR-A800 as shown in example. In addition, all other components with in the safety stop loop shall be 'safety approved' types.

WARNING

- To avoid an electric shock hazard, insert the magnetic contactor (MC) between power source and drive.
- Open the contact of MC and keep away from drive for discharging time (refer to your drive's User Manual for information) before performing any work on the drive. And verify that the voltage on the bus capacitors has discharged before Measuring the DC bus voltage at the P(+) and N(-) terminals or test points (refer to your drive's [User Manual](#) for locations). The voltage must be zero.

CAUTION

- To avoid systematic faults, a test even for faulty demands of the safety function has to be performed in order to check the correct function of the monitor signal. This test shall be carried out at system installation, any software changes, parameterization changes, and/or at least once per year. Refer to '4. Test and checking failure'.

●Wiring

The safety related terminals are described in Table.2 and Table.3

Table.2 The safety related terminals

| Terminal symbol | Description | Rating *1 |
|-----------------|--|--|
| S1 | For input of safety stop channel 1. S1-SIC is Open: In safety stop mode. Short: Non safety stop mode. | Input resistance: 4.7kΩ Input current : 4 to 6 mADC (In case of 24VDC input) |
| S2 | For input of safety stop channel 2. S2-SIC is Open: In safety stop mode. Short: Non safety stop mode. | |
| SIC | Common terminal for S1 terminal and S2 terminal. | |
| SO | As output for failure detection and alarm. SO terminal type is 'Open collector output'. SO-SOC is OFF(Open): Detect failure or alarm. ON(Close): No failure detected. Note: This terminal cannot be used to output safety outputs in a safety system. This terminal can be used for alarm or to prevent restart only, no other safety function. | Load: 24VDC/0.1A max. Voltage drop: 3.4V max. (In case of 'ON' state) |
| SOC | Common terminal for SO terminal. | |

*1 Specifications for conforming safety standards.

Table.3 Truth table of safety related signals

| Input power | S1-SIC | S2-SIC | Internal safety circuit *1 | SO-SOC | Inverter operation state |
|-------------|--------|--------|----------------------------|----------------------------|----------------------------|
| OFF | - | - | - | OFF(Open) | Drive shutoff (Safe state) |
| ON | Short | Short | No failure | ON(Close) | Drive enable |
| | | | Failure | OFF(Open) | Drive shutoff (Safe state) |
| | Open | Open | No failure | ON(Close) | Drive shutoff (Safe state) |
| | | | Failure | OFF(Open) | Drive shutoff (Safe state) |
| | Short | Open | N/A | OFF(Open) | Drive shutoff (Safe state) |
| Open | Short | N/A | OFF(Open) | Drive shutoff (Safe state) | |

"N/A" denotes a condition where circuit fault does not apply.

*1 At an internal safety circuit fault, one of E.OPT, E.OP1, E.PE, E.RET, E.PE2, E.CTE, E.P24, E.SAF, E.OS, E.OSD, E.ECT, E.OD, E.MB1 to E.MB7, E.EP, E.CPU, E.5, E.6, E.7, E.13 is displayed on the operation panel. SA is displayed on the operation panel while S1 and S2 signals are both open and the safety function operates (without internal safety circuit fault).

NOTE

- The response time from safety stop signal input to drive shutoff (safe state) is faster than 8ms.
- Hold the ON or OFF status for 2ms or longer to input signal to terminal S1 or S2.
Signal input shorter than 2ms is not recognized.

●Wire and ferrule specification

Table.4 Wire and ferrule specification

| Wire size (mm ²) | Ferrule with insulation collar *1 | Crimping tool name *1 |
|------------------------------|-----------------------------------|-----------------------|
| 0.3 / 0.5 | AI 0,5-10WH | CRIMPFOX 6 |
| 0.75 | AI 0,75-10GY | |
| 1 | AI 1-10RD | |
| 1.25 / 1.5 | AI1,5-10BK | |
| 0.75 (combined 2 wire) | AI TWIN 2 X 0,75-10GY | |

*1 Ferrules and tools are distributed by Phoenix Contact.

●Jumper cable

The jumper cable between S1,S2 and PC terminal between SIC and SD terminal has been installed in the factory as shown in Fig.2.

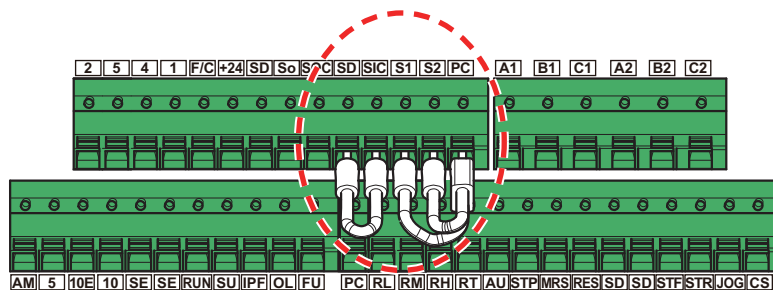

Terminal block of FR-A800

Fig.2. Short wire

Before connecting safety input wire to S1,S2 and SIC terminal, remove this jumper cable.

3 EXAMPLE OF SAFETY SYSTEM CONFIGURATION

•FR-A800 configuration example

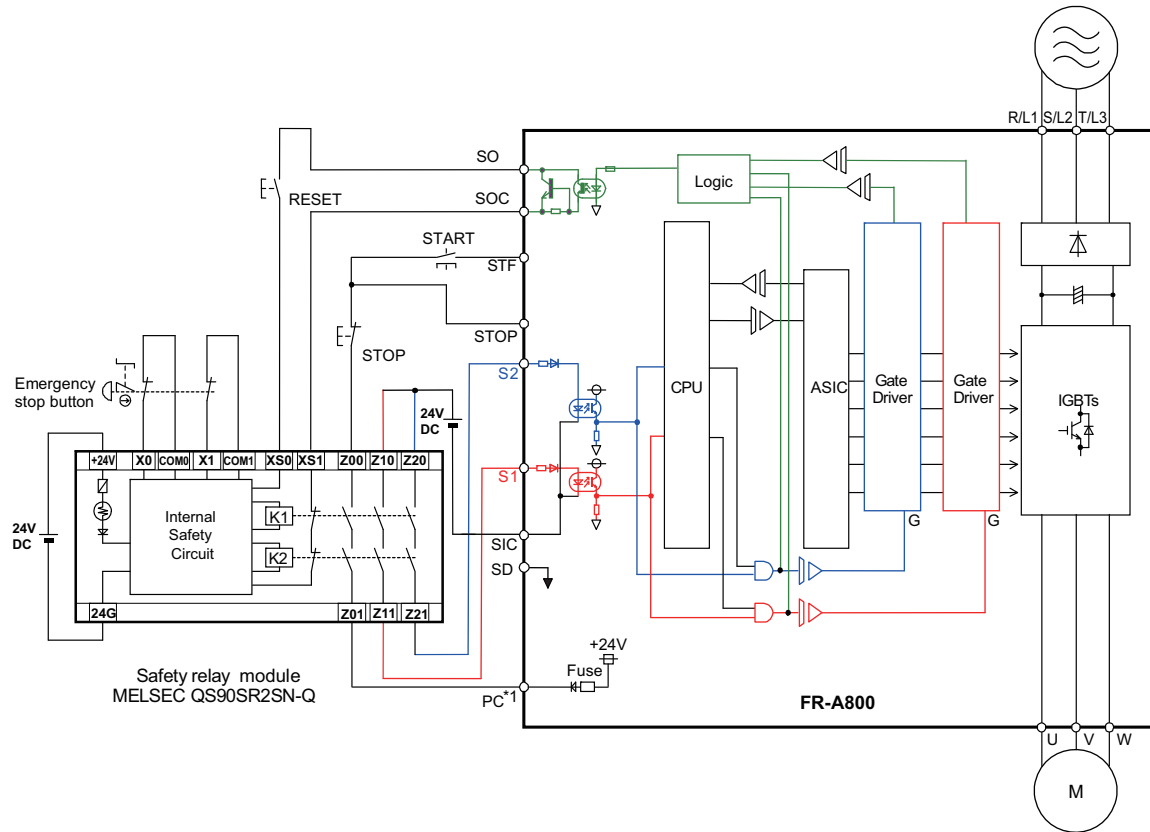

*1 If the control logic is SINK logic, the common terminal is terminal SD.

Fig.3 Safety system example with FR-A800

NOTE

- When starting up the system's operation, press the RESET switch to reset the safety stop function first, then turn ON the START switch to run the motor.
- In the above configuration, after reset of emergency stop button, drive will be in safe-state until RESET switch is pressed.

CAUTION

- To prevent restart in case of recovering from input power loss of drive, 3-wired connection for START/STOP control is recommended. In case of 2-wire connection and using latching type switch to short between STF and SD/PC for starting, ensure the compliance with safety requirement for the restarting when the drive recover from input power loss.

• Multiple inverter configuration example

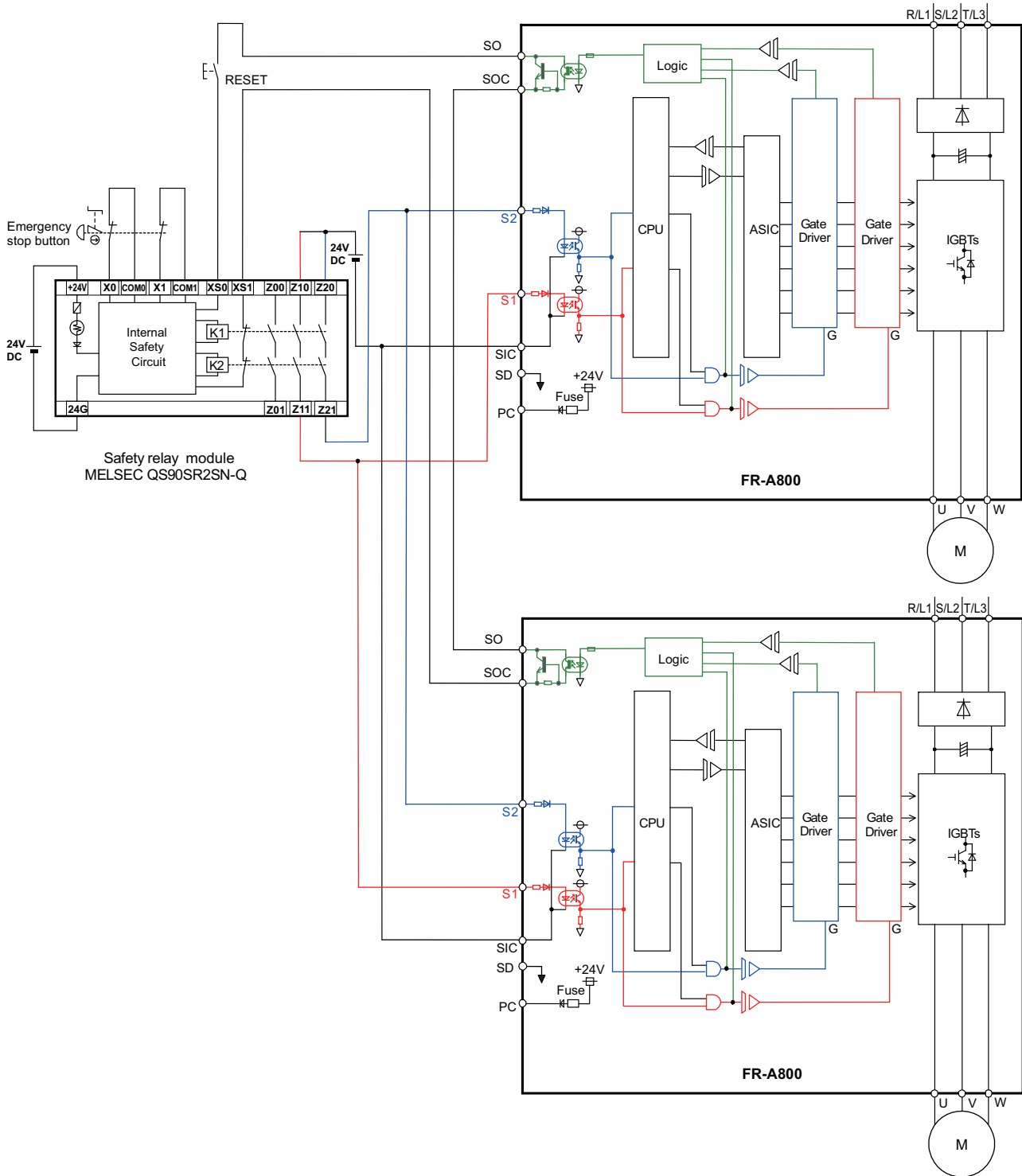

Fig.4 When using multiple safety stop function inverters (FR-A800)

NOTE

- Some models cannot be used together because their control logics are different. Refer to the [SAFETY STOP FUNCTION MANUAL](#) of each model.

● Safety controller configuration example

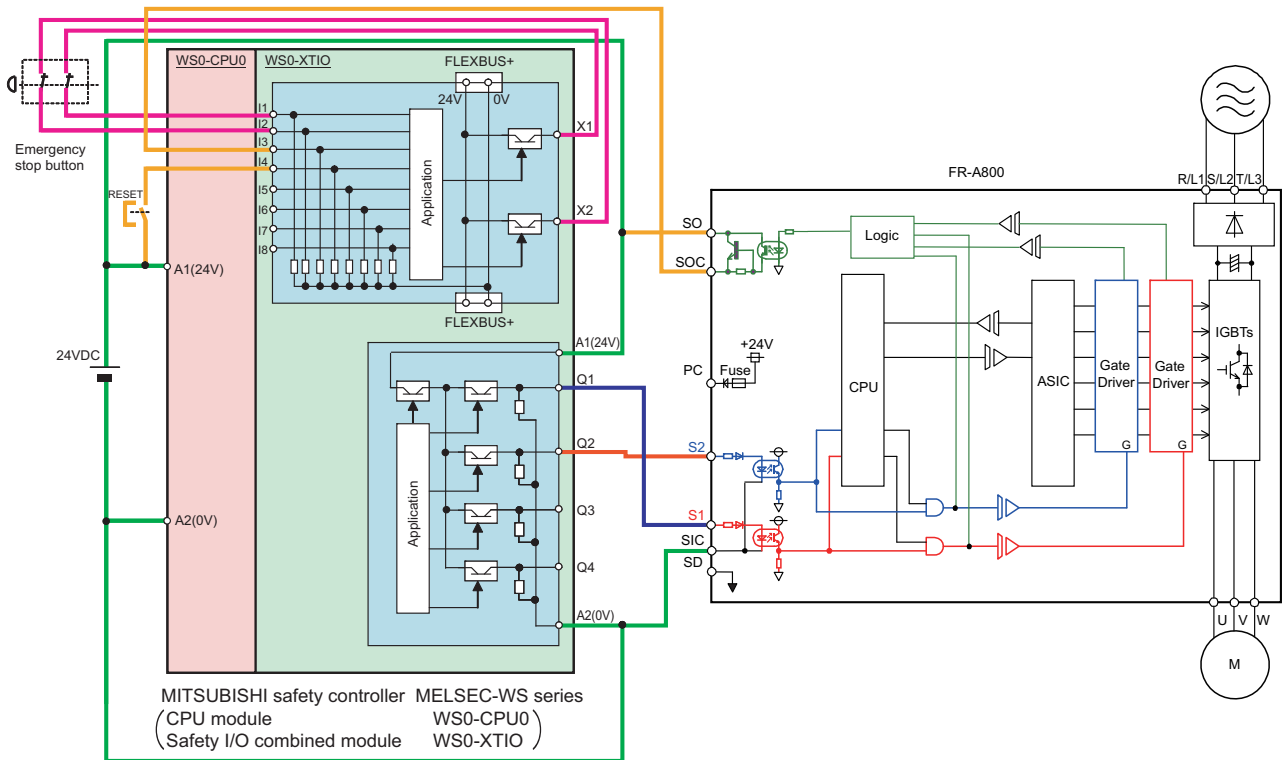

Fig.5 Safety system example with FR-A800

NOTE

- When starting up the system's operation, press the RESET switch to reset the safety stop function first.
- In the above configuration, after reset of emergency stop button, drive will be in safe-state until RESET switch is pressed.

4 TEST AND CHECKING FAILURE

CAUTION

- To avoid systematic faults, a test even for faulty demands of the safety function has to be performed in order to check the correct function of the monitor signal. This test shall be carried out at system installation, any software changes, parameterization changes, and/or at least once per year.

I/O status and failure

FR-A800 safety related I/O status obeys the following truth table.

Table.5 Truth table of safety related signals

| Input power | S1-SIC | S2-SIC | Internal safety circuit *1 | SO-SOC | Inverter operation state |
|-------------|--------|--------|----------------------------|-----------|----------------------------|
| OFF | - | - | - | OFF(Open) | Drive shutoff (Safe state) |
| ON | Short | Short | No failure | ON(Close) | Drive enable |
| | | | Failure | OFF(Open) | Drive shutoff (Safe state) |
| | Open | Open | No failure | ON(Close) | Drive shutoff (Safe state) |
| | | | Failure | OFF(Open) | Drive shutoff (Safe state) |
| | Short | Open | N/A | OFF(Open) | Drive shutoff (Safe state) |
| | Open | Short | N/A | OFF(Open) | Drive shutoff (Safe state) |

"N/A" denotes a condition where circuit fault does not apply.

- *1 At an internal safety circuit fault, one of E.OPT, E.OP1, E.PE, E.RET, E.PE2, E.CTE, E.P24, E.SAF, E.OS, E.OSD, E.ECT, E.OD, E.MB1 to E.MB7, E.EP, E.CPU, E.5, E.6, E.7, E.13 is displayed on the operation panel. SA is displayed on the operation panel while S1 and S2 signals are both open and the safety function operates (without internal safety circuit fault).

In case of diagnostic or functionality test, check the I/O state whether it is same or not as Table.5.

Diagnostic

If the failure detected, FR-A800 output alarm signal and indicate 'E.SAF' at the display.

In case of FR-A800 output the alarm, please take following action.

- 1) Check the S1-SIC and S2-SIC input signal logic is the same. If these are different logic, collect the input signal and reset the FR-A800.
- 2) Disconnect the wire from S1, S2, SIC terminal, then reset or power-off and on. If the 'SA' letter is flashed up at display, there is failure in system except FR-A800. But, still 'E.SAF' is displayed and alarm output, there is malfunction on FR-A800.

Self diagnostic test

FR-A800 does the self-diagnostic test on the power-ON.

If FR-A800 output alarm (SA, E.SAF) at power-up, please take the action described in 'Diagnostic' at above.

Test procedure for functionality

As depicted 'CAUTION' in above, the test for the functionality is important.

Please do the test following procedure.

- 1) Please make each state of S1-SIC and S2-SIC depicted at Table.5.
- 2) If there is any different state from Table.5, FR-A800 has some malfunction.
- 3) If there is no different state from Table.5, check the systematic performance, such as, press the emergency switch, press the start/restart button at the failure detected (SO-SOC opened), and so on.
- 4) Finally clear the error record of the FR-A800 (see the user manual how to clear the error record).

5 SAFETY PARAMETERS OF FR-A800

The safety parameters of FR-A800 are depicted as follows.

Table.6 Safety parameters of FR-A800

| Parameter | Value |
|--------------------|-----------------------|
| PFD _{AVG} | 5.13×10^{-4} |
| PFHD | 5.85×10^{-9} |
| PL | d |
| MTTF _D | 674 years |
| DC _{AVG} | 60% |

REVISIONS

| Print Date | Manual Number | Revision |
|------------|---------------------|---|
| Apr. 2013 | BCN-A23228-001(E) | First edition |
| Jun. 2013 | BCN-A23228-001-A(E) | Modification ● Multiple inverter configuration example |
| | | |

| HEADQUARTERS | EUROPEAN REPRESENTATIVES | EUROPEAN REPRESENTATIVES | EUROPEAN REPRESENTATIVES |
|--|--|--|--|
| MITSUBISHI ELECTRIC EUROPE EUROPE B.V. German Branch Gothaer Straße 8 D-40880 Ratingen Phone: +49 (0) 21 02 / 486-0 Hotline: +49 2102 1805 000-765 /-766 Fax: +49 (0) 21 02 / 4 86-1 12 0 e mail: megfa-mail@meg.mee.com www.mitsubishi-automation.com | GEVA AUSTRIA Wiener Straße 89 A-2500 Baden Phone: +43 (0) 2252 / 85 55 20 Fax: +43 (0) 2252 / 488 60 e mail: office@geva.co.at | MITSUBISHI ELECTRIC IRELAND EUROPE B.V.-Irish Branch Westgate Business Park Ballymount IRL-Dublin 24 Phone: +353 (0) 1 / 419 88 00 Fax: +353 (0) 1 / 419 88 90 e mail: sales.info@meuk.mee.com | Beijer Electronics AB SWEDEN Box 426 S-20123 Malmö Phone: +46 (0) 40 / 35 86 00 Fax: +46 (0) 40 / 93 23 02 e mail: — |
| MITSUBISHI ELECTRIC FRANCE FRANCE 25, Boulevard des Bouverts F-92741 Nanterre Cedex Phone: +33 1 55 68 55 68 Fax: +33 1 49 01 07 25 e mail: factory.automation@fra.mee.com | Getronics b.v. BELGIUM Control Systems Pontbeeklaan 43 B-1731 Asse-Zellik Phone: +32 (0) 2 / 4 67 17 51 Fax: +32 (0) 2 / 4 67 17 45 e mail: infoautomation@getronics.com | ALFATRADE LTD. MALTA 99 Paola Hill Paola PLA 08 Phone: +356 / 697816 Fax: +356 / 697817 e mail: paul.licari@alfatrx.com | ECONOTEC AG SWITZERLAND Postfach 282 CH-8309 Nürensdorf Phone: +41 (0) 1 / 838 48 11 Fax: +41 (0) 1 / 838 48 12 e mail: — |
| MITSUBISHI ELECTRIC ITALY EUROPE B.V. Italian Branch C.D. Colleoni-P. Perseo Ing. 2 Via Paracelso 12 I-20041 Agrate Brianza (MI) Phone: +39 (0) 39 / 60 53 1 Fax: +39 (0) 39 / 60 53 312 e mail: factory.automation@it.mee.com | TELECON CO. BULGARIA 4, A. Ljapchev Blvd. BG-1756 Sofia Phone: +359 92 / 97 44 05 8 Fax: +359 92 / 97 44 06 1 e mail: — | Getronics bv NETHERLANDS Control Systems Donauweg 10 NL-1043 AJ-Amsterdam Phone: +31 (0) 20 / 586 15 92 Fax: +31 (0) 20 / 586 19 27 e mail: infoautomation@getronics.com | GTS TURKEY Darülaceze Cad. No. 43A KAT: 2 TR-80270 Okmeydani-Istanbul Phone: +90 (0) 212 / 320 1640 Fax: +90 (0) 212 / 320 1649 e mail: — |
| MITSUBISHI ELECTRIC SPAIN EUROPE B.V. Pol. Ind. Can Magi-C. Calle Joan Buscallá, 2-4 AC 420 E-08190 Sant Cugat del Vallés Phone: +34 (9) 3 / 565 31 31 Fax: +34 (9) 3 / 589 29 48 | AutoCont CZECHIA Control Systems s.r.o. Nemocnici 12 CZ-70200 Ostrava 2 Phone: +420 (0) 69 / 615 21 11 Fax: +420 (0) 69 / 615 21 12 e mail: — | MPL Technology SP.Z.o.o POLAND ul.Wroclawska 53 PL-30-011 Kraków Phone: +48 (0) 12 / 632 28 85 Fax: +48 (0) 12 / 632 47 82 e mail: krakow@mpl.com.pl | STC Drive Technique RUSSIA Poslannikov per., 9, str. 1 RUS-107005 Moskow Phone: +7 (0) 95 / 786 21 00 Fax: +7 (0) 95 / 786 21 01 e mail: — |
| MITSUBISHI ELECTRIC UK EUROPE B.V. UK Branch Travellers Lane Hatfield, Hertfordshire, AL10 8 XB Phone: +44 (0) 1707 / 27 61 00 Fax: +44 (0) 1707 / 27 86 95 | louis poulsen DENMARK industri & automation Geminivej 32 DK-2670 Greve Phone: +45 (0) 43 / 95 95 95 Fax: +45 (0) 43 / 95 95 91 e mail: lpia@lpmail.com | Sirius Trading&Services srl ROMANIA Bd. Ghica nr. 112, Bl. 41 RO-72335 Bucuresti 2 Phone: +40 (0) 1 / 210 55 11 Fax: +40 (0) 1 / 210 55 11 e mail: sirius_t_s@fx.ro | JV-CSC Automation UKRAINE 15, M. Raskovoyi St., Floor 10, Office 1010 U-02002 Kiev Phone: +380 (4) 4 / 238 83 16 Fax: +380 (4) 4 / 238 83 17 e-Mail: mkl@csc-a.kiev.ua |
| MITSUBISHI ELECTRIC JAPAN CORPORATION Tokyo Bldg. 2-7-3 Marunouchi Chiyoda-Ku Tokyo 100-8310 Phone: +81 (0) 3 / 32 18 31 76 Fax: +81 (0) 3 / 32 18 24 22 | UTU Elektrotehnika AS ESTONIA Pärnu mnt. 160i EE-10621 Tallinn Phone: +372 6 / 51 72 80 Fax: +372 6 / 51 72 88 e mail: utu@utu.ee | ACP AUTOCOMP a.s. SLOVAKIA Chalupkova 7 SK-81109 Bratislava Phone: +421 (0) 7 592 22 54 Fax: +421 (0) 7 592 22 48 e mail: — | MIDDLE EAST REPRESENTATIVE SHERF Motion Techn. LTD ISRAEL Rehov Hamerkava 19 IL-58851 Holon Phone: +972 (0) 3 / 559 54 62 Fax: +972 (0) 3 / 556 01 82 e mail: — |
| MITSUBISHI ELECTRIC USA AUTOMATION 500 Corporate Woods Parkway Vernon Hills, Illinois 60061 Phone: +1 (0) 847 / 478 21 00 Fax: +1 (0) 847 / 478 03 27 | URHO TUOMINEN OY FINLAND Hevoshaankatu 3 FIN-28600 Pori Phone: +358 (0) 2 / 55 08 00 Fax: +358 (0) 2 / 55 088 41 e mail: — | INEA d.o.o. SLOVENIA Ljubljanska 80 SI-1230 Domžale Phone: +386 (0) 17 21 80 00 Fax: +386 (0) 17 24 16 72 e mail: inea@inea.si | |



MITSUBISHI ELECTRIC CORPORATION

HEAD OFFICE: TOKYO BUILDING 2-7-3, MARUNOUCHI, CHIYODA-KU, TOKYO 100-8310, JAPAN